

100	MOTOR	-	1		
69	NAME PLATE	AL	1		
63	HEXAGON SOCKET HEAD CAP SCREW	SUS304	4 <sup>S</sup>		with WASHER
62	HEXAGON SOCKET HEAD CAP SCREW	SUS304	6 <sup>S</sup>		with WASHER
61	SET SCREW	SCM435	1		M4
45	BUSHING	SiC-D	1		
33	O RING	PTFE	1		JIS B 2401 C60
29	THRUST RING	SiC	1		
20B	MAGNET MAGNET COUPLING (M)	RARE EARTH SS400	1 <sup>S</sup> 1		
15	FRAME ADAPTER	FC200	1		
8	SHAFT	SiC	1		
4	REAR CASING	SUS304	1		
2	CASING	SCS13	1		
20A	MAGNET MAGNET COUPLING (P)	RARE EARTH SUS304	1 <sup>S</sup> 1		
1A	PIN	SUS304	1		φ3×7L
1	IMPELLER	SCS13	1		
MARK	NAME OF PART	MAT'L	USE No.REQ'D	SPARE WT.	REMARK.

NAME OF PART	MAT'L	QTY.
ACCESSORIES		

REV.		
APP'D	H.Miyakoshi	CH. M.Murakami
CHIEF	<i>SM</i>	DWN. M.Murakami
CH'D	M.Murakami	DATE 2019.05.14

PUMP CODE	
MA25-B54	
MAGNETIC DRIVE CENTRIFUGAL PUMP	
SECTIONAL DRAWING	
3rd ANGLE PROJECTION	SCALE <input checked="" type="checkbox"/>
SANWA HYDROTECH CORP.	

WORK No.	
QTY.	
DWG.No.	MA25-B54-0
REV.	

承  
審  
品  
機  
組  
控  
計

PUMP DATA SHEET					WORK No.				
1	CUSTOMER				DATE		2019/5/13		
2	USER				AUTH. BY	CHKD BY	MADE BY		
3	EQUIP' T NAME				H. Miyakoshi	M. M	M. Murakami		
4	ORDER No.				REV. DATE	LINE No.	BY		
5	JOB No.				 2020/4/1	25	M. Murakami		
6	ITEM (PUMP) No.								
7	PUMP NAME								
8	QUANTITY								
9	OPERATING CONDITIONS				CONSTRUCTION				
10	LIQUID				PUMP CODE	MA25-B54			
11	SLURRY				MAGNET TYPE	Q15x4N			
12		(wt%)	(mm)		BEARING	RADIAL :	-	THRUST :	-
13	PH				AUXILIARY PIPING	-			
14	PUMPING TEMP.	(-20~130)		( °C )	NOZZLE	SIZE	RATING	FACING	
15	SPEC. GRAVITY	@P. T.	1		SUCTION	1/2"	R	-	
16	VAPOUR PRESS.	@P. T.			DISCHARGE	1/2"	R	-	
17	VISCOSITY	@P. T.	1	(mPa · s)	IMPELLER DIA. DES.	φ50		(mm)	
18	CAPACITY	0.6	(m3/hr)	10	(l/min)	ROTATION VIEWED FROM CPLG END	<input checked="" type="checkbox"/> CW	<input type="checkbox"/> CCW	
19	DISCH. PRESS.				(MPaG)	PERFORMANCE			
20	SUCT. PRESS.				(MPaG)	SPEED	2800	(rpm)	
21	DIFF. PRESS.				(MPa)	NPSH REQ'D (WATER)	-	( m )	
22	TOTAL HEAD	2.5			( m )	DES. EFF.	30	( % )	
23	NPSH AVAIL.				( m )	DES. BHP	0.014	( kW )	
24	CASE DES. TEMP.	130	(°C)	PRESS.	0.6	(MPaG)	MIN. CONTINUOUS FLOW	0.09 (m3/hr) 1.5 (l/min)	
25	INSTALLATION	<input type="checkbox"/>	INDOOR	<input type="checkbox"/>	OUTDOOR				
26	MOTOR				MATERIALS				
27	TYPE	単相インダクションモーター	FORM	フランジ形	CASING	SCS13			
28		IM-F8B25SFS750			IMPELLER	SUS304			
29	SPEED	3000 (SYN)			(rpm)	BUSHING, THRUST RING	SiC-D, SiC		
30	VOLTS/CYCLE	100	( V )	50	( Hz )	SHAFT (HF)	SiC ( - )		
31	RATED OUTPUT/POLES	0.025	( kW )	2	( P )	GASKET	---		
32	FRAME	51	MFR.	株式会社サテック		O RING	PTFE		
33	PUMP PAINTING								
34	COLOR	BODY:	2.5PB4/10	COVER:	---				
35	REMARKS								
36									
37									
38									
39									
40									



# ＜試験成績表＞

発行日: 2019.05.13

CODE : MA25-B54  
 PUMP TYPE : MA  
 PUMP SIZE : 25

規格要目	指定揚液 (温度 [°C]、比重、粘度) -/1/1 [mPa·s]	吐出量 (ℓ/min) 10	全揚程 (m) 2.5	回転速度 (min-1) 2800	原動機出力 (kW) 0.025	NPSH <sub>Av</sub> /Req (m) -/
------	---------------------------------------	-------------------	----------------	----------------------	---------------------	-----------------------------------

計測項目		1	2	3	4	5	6	7	8
回転速度 (min-1)		3249	3190	3106	3004	2934			
水温 (°C)		15.0	15.0	15.0	15.0	15.0			
吐出量	測定器の読み (ℓ/min)	0.0	5.0	10.0	15.0	19.0			
	吐出量 (ℓ/min)	0.0	5.0	10.0	15.0	19.0			
揚程	吐出しヘッド (m)	4.2	4.2	3.7	2.2	0.8			
	吸込ヘッド (m)	0.42	0.41	0.40	0.39	0.37			
	測点高差 (m)	0.00	0.00	0.00	0.00	0.00			
	速度ヘッド (m)	0.000	0.000	0.000	0.000	0.000			
	全揚程 (m)	3.8	3.8	3.3	1.8	0.4			
理論動力 (kW)		0.000	0.003	0.005	0.004	0.001			
周波数 (Hz)		60.0	60.0	60.0	60.0	60.0			
電動機	電圧 (V)	102.8	102.9	102.4	102.4	102.5			
	電流 (A)	0.381	0.411	0.446	0.485	0.518			
	入力 (kW)	0.039	0.042	0.045	0.050	0.053			
	効率 (%)	47.0	49.6	51.3	52.1	52.6			
	出力 (kW)	0.018	0.021	0.023	0.026	0.028			
軸動力 (kW) (比重=1)		0.018	0.021	0.023	0.026	0.028			
ポンプ効率 (%)		0.0	14.8	23.3	17.0	4.8			
回転換算	吐出量 (ℓ/min)	0.0	4.4	9.0	14.0	18.1			
	全揚程 (m)	2.8	2.9	2.7	1.6	0.4			
	軸動力 (kW)	0.012	0.014	0.017	0.021	0.024			
粘度換算	吐出量 (ℓ/min)								
	全揚程 (m)								
	軸動力 (kW)								
	ポンプ効率 (%)								
	マグネットポンプ効率 (%)								

電動機要目	
形式	IM-F8B25SF5750
出力	( 0.025 kW)
周波数 (Hz)	( 50 Hz)
電圧	( 100 V)
電流	( 0.55 A)
極数	( 2 P)
回転速度	( 3000min-1)
製造番号	10J117
製造業者名	横河
試験揚液	常温清水
吐出量測定方法	電磁流量計
室温	( 18 °C)
連続運転時間	( 60 min)
軸受温度	
軸継手側	( - °C)
反対側	( - °C)
インペラー径	( 50.0 mm)
マグネット形式	Q15x4N
キャンロス	( 0.001 kW)
備考	
試験者名	寺地
製造業者名	三和ハイドロテック(株)

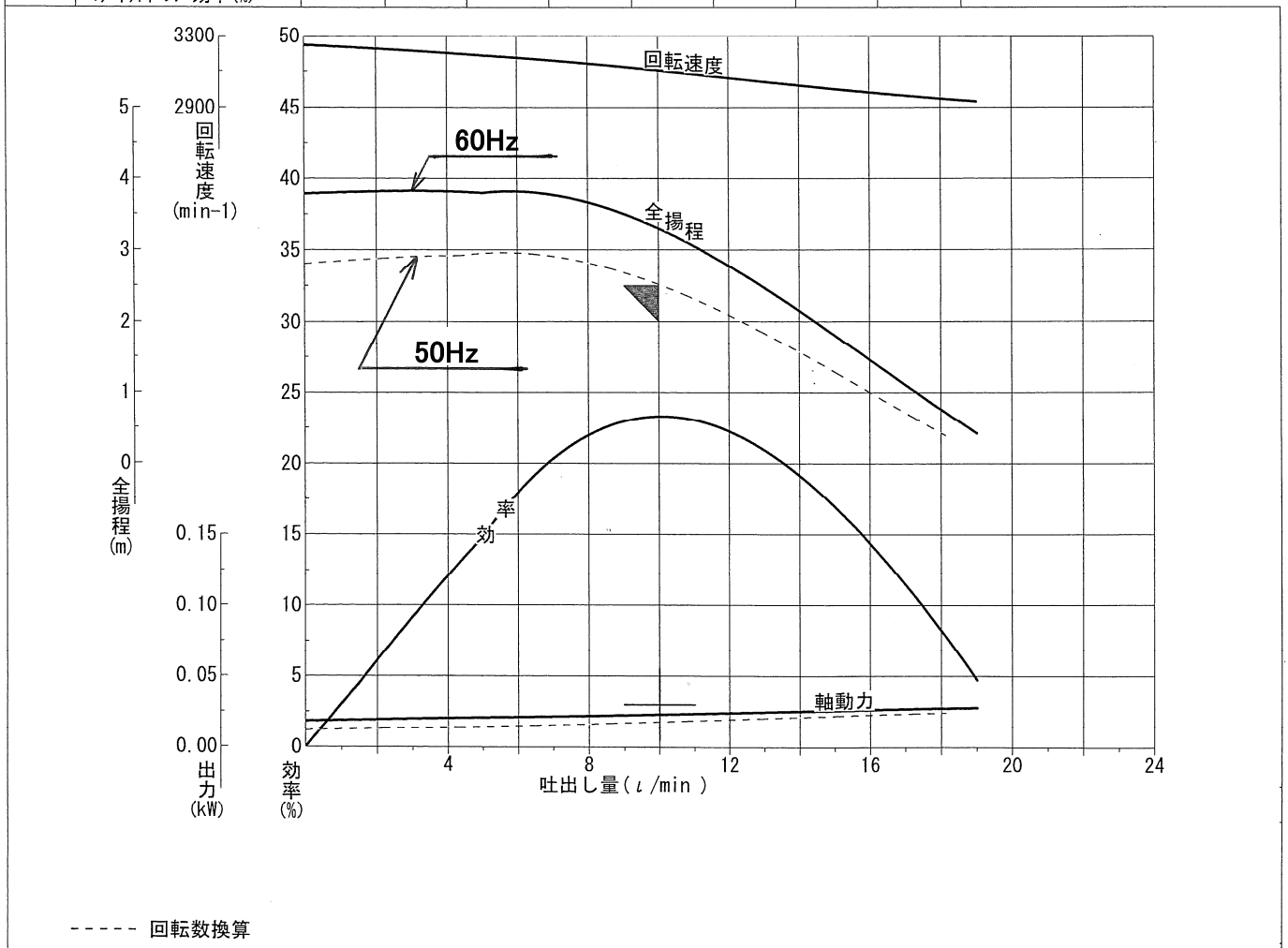

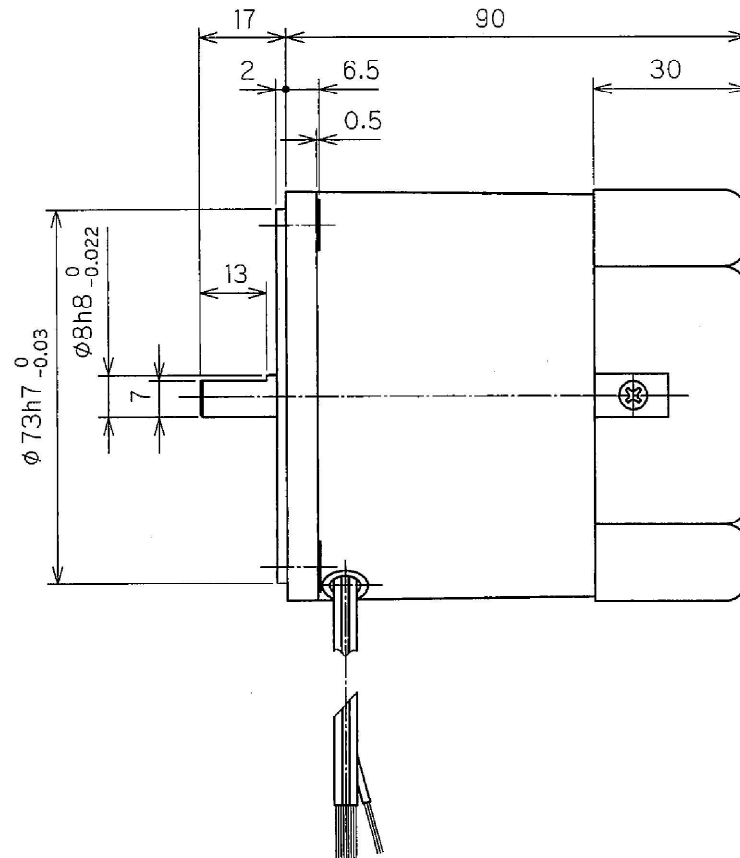
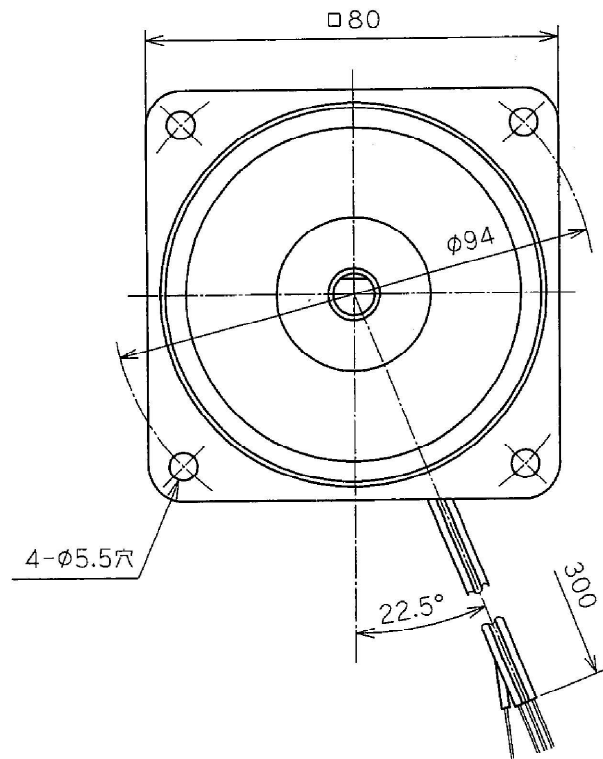

Rev.3	2011.10.07	DESCRIPTION	社名変更・全面書替		FZ2-
ISSUE	サーテック 技術部	AUTHOR	奥山	CHECK	APPROVAL 奥山
Rev.2	2006.06.28	DESCRIPTION	図面枠変更・全面書替		FZ2-
ISSUE	藤冠サーテック 技術部	AUTHOR	奥山	CHECK 奥山	APPROVAL 奥山
Rev.0	2000.01.11	DESCRIPTION	新規発行		FZ2-
ISSUE	藤冠サーテック 技術部	AUTHOR	大貫倉	CHECK 田野倉	APPROVAL 奥山
TITLE IM-F8B25SFS750 (DIMENSIONS)					NO. - D11901
					REVISION 3
					PAGE 1