

MOTOR	
FRAME SIZE	OUTPUT (kW)
71M	0.4

MASS APPROX (kg)		
PUMP	MOTOR	TOTAL
11	9.5	20.5



① CASING DRAIN ; Rc1/4 (PLUG)

REV.	
△	2020.4.20 Y.K
△	2021.07.07 A.E
APP'D	T.Shimayoshi
CH.	A.Endo
CHIEF	M.Murakami
DWN.	M.Murakami
CH'D	S.Okamoto
DATE	2019.05.10

PUMP CODE	
MMP21-B54	
MAGNETIC DRIVE	
CENTRIFUGAL PUMP	
OUTLINE DIMENSIONS	
3rd ANGLE PROJECTION	SCALE

WORK No.	
	QTY.
DWG.No.	REV.
MMP21-B54-X	2

承	
資	
品	1
機	
組	1
控	
計	

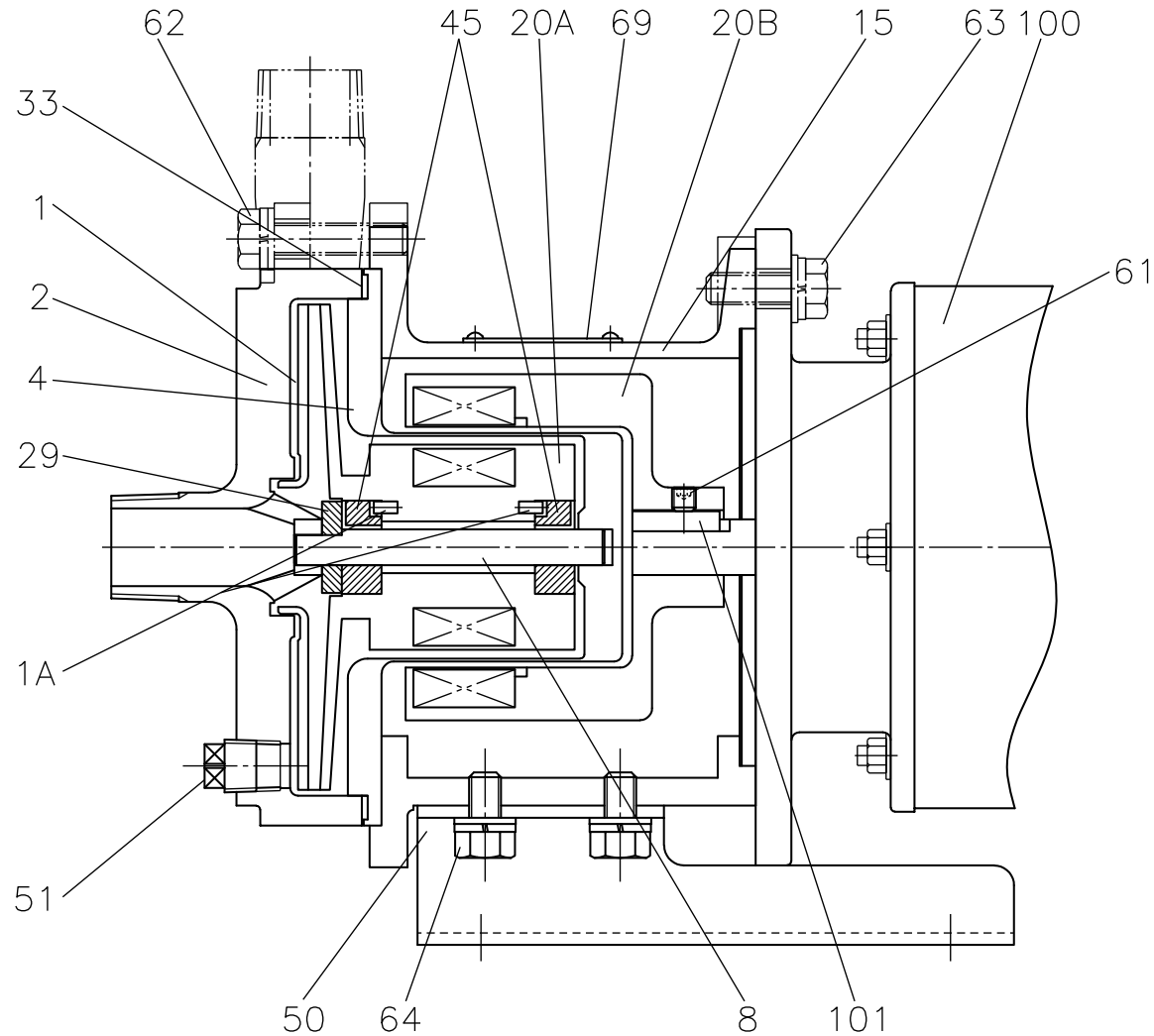

101	COUPLING KEY	S45C	1		
100	MOTOR	-	1		
69	NAME PLATE	SUS304	1		
64	HEXAGON HEAD BOLT	SUS304	4 ^s		with WASHER
63	HEXAGON HEAD BOLT	SUS304	4 ^s		with WASHER
62	HEXAGON HEAD BOLT	SUS304	8 ^s		with WASHER
61	SET SCREW	SCM435	1		
51	PLUG	SUS316	1		
50	BASE	SUS304	1		
45	BUSHING	SiC-D	2		
33	GASKET	PTFE	1		φ125xφ136x1.5t
29	THRUST RING	SiC	1		
	MAGNET	RARE EARTH	1 ^s		
20B	MAGNET COUPLING(M)	FCD	1		R25x6N
15	FRAME ADAPTER	FC200	1		
8	SHAFT	SiC	1		
4	REAR CASING	SUS304	1		
2	CASING	SCS13	1		
	MAGNET	RARE EARTH	1 ^s		
20A	MAGNET COUPLING(P)	SUS316	1		R25x6N
1A	PIN	SUS316	2		
1	IMPELLER	SCS13	1		
MARK	NAME OF PART	MAT'L	USE SPARE No. REQ'D	WT.	REMARK.

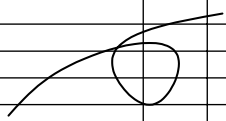
		
NAME OF PART	MAT'L	QTY.
ACCESSORIES		

REV.	
▲2021.08.10 A.F	
APP'D	T.Shimayoshi
CHIEF	M.Murakami
CH'D	S.Okamoto
CH.	A.Endo
DWN.	M.Murakami
DATE	2018.02.15

PUMP CODE	
MMP21-B54	
MAGNETIC DRIVE CENTRIFUGAL PUMP	
SECTIONAL DRAWING	
3rd ANGLE PROJECTION	SCALE 
SANWA HYDROTECH CORP.	

WORK No.	
QTY.	
DWG.No.	REV.
MMP21-B54-0 1	1
機組	
控計	

承
資
品
機
組
控
計

PUMP DATA SHEET					WORK No.				
1	CUSTOMER				DATE		2019/6/26		
2	USER				AUTH. BY	CHKD BY	MADE BY		
3	EQUIP' T NAME				H. Miyakoshi	M. M	M. Murakami		
4	ORDER No.				REV. DATE	LINE No.	BY		
5	JOB No.				△1 2020/4/1	25	M. Murakami		
6	ITEM (PUMP) No.				△2 2021/7/16	27	Y. Kinoshita		
7	PUMP NAME								
8	QUANTITY								
9	OPERATING CONDITIONS				CONSTRUCTION				
10	LIQUID				PUMP CODE	MMP21-B54			
11	SLURRY				MAGNET TYPE	R25x6N			
12		(wt%)	(mm)		BEARING	RADIAL :	-	THRUST :	-
13	PH				AUXILIARY PIPING	-			
14	PUMPING TEMP.	(-20~130)	(°C)		NOZZLE	SIZE	RATING	FACING	
15	SPEC. GRAVITY	@P. T.	1		SUCTION	3/4"	R	-	
16	VAPOUR PRESS.	@P. T.			DISCHARGE	3/4"	R	-	
17	VISCOSITY	@P. T.	1	(mPa · s)	IMPELLER DIA. DES.	φ122 (mm)			
18	CAPACITY	2.4	(m3/hr)	40 (l/min)	ROTATION VIEWED FROM CPLG END	■CW □CCW			
19	DISCH. PRESS.				PERFORMANCE				
20	SUCT. PRESS.				SPEED	2920 (rpm)			
21	DIFF. PRESS.				NPSH REQ' D (WATER)	- (m)			
22	TOTAL HEAD	15			DES. EFF.	29 (%)			
23	NPSH AVAIL.				DES. BHP	0.34 (kW)			
24	CASE DES. TEMP.	130	(°C)	PRESS.	0.6	(MPaG)	MIN. CONTINUOUS FLOW	0.18 (m3/hr)	3 (l/min)
25	INSTALLATION	<input type="checkbox"/>	INDOOR	<input type="checkbox"/>	OUTDOOR				
26	MOTOR				MATERIALS				
27	TYPE	IK	FORM	FCKLAW21E	CASING	SCS13			
28					IMPELLER	SUS304			
29	SPEED	3000	(SYN)	(rpm)	BUSHING, THRUST RING	SiC-D, SiC			
30	VOLTS/CYCLE	200	(V)	50	(Hz)	SHAFT (HF)	SiC (-)		
31	RATED OUTPUT/POLES	0.4	(kW)	2	(P)	GASKET	PTFE		
32	FRAME	71	MFR.	TOSHIBA	O RING	---			
33	PUMP PAINTING								
34	COLOR	BODY:	2.5PB4/10	COVER:	---				
35	REMARKS								
36									
37									
38									
39									
40									



<試験成績表>

発行日: 2019.05.13
Rev.1 : 2020.04.01
Rev.2 : 2022.05.25

CODE : MMP21-B54/B56
PUMP TYPE : MMP
PUMP SIZE : 21

規格要目	指定揚液 (温度[°C]、比重、粘度) -/1/1[mPa·s]	吐出量 (L/min) 40	全揚程 (m) 15	回転速度 (min-1) 2920	原動機出力 (kW) 0.400	NPSHv/Req (m) -/
------	-------------------------------------	-------------------	---------------	----------------------	---------------------	---------------------

計測項目		1	2	3	4	5	6	7	8
回転速度 (min-1)		2903	2865	2826	2803	2782			
水温 (°C)		18.8	18.8	18.8	18.8	18.8			
吐出量	測定器の読み (L/min)	0.0	20.0	40.0	50.0	60.0			
	吐出量 (L/min)	0.0	20.0	40.0	50.0	60.0			
揚程	吐出しヘッド (m)	21.6	18.5	16.2	12.1	6.8			
	吸込ヘッド (m)	0.49	0.45	0.33	0.23	0.13			
	測点高差 (m)	0.00	0.00	0.00	0.00	0.00			
	速度ヘッド (m)	0.000	0.000	0.000	0.000	0.000			
	全揚程 (m)	21.1	18.1	15.9	11.9	6.7			
理論動力 (kW)		0.000	0.059	0.103	0.097	0.065			
周波数 (Hz)		50.0	50.0	50.0	50.0	50.0			
電動機	電圧 (V)	201.6	201.1	200.4	200.9	200.3			
	電流 (A)	1.117	1.338	1.589	1.706	1.821			
	入力 (kW)	0.247	0.320	0.395	0.430	0.463			
	効率 (%)	72.4	75.5	76.6	76.6	76.6			
	出力 (kW)	0.179	0.241	0.303	0.330	0.355			
軸動力 (kW) (比重=1)		0.179	0.241	0.303	0.330	0.355			
ポンプ効率 (%)		0.0	24.4	34.2	29.4	18.4			
回転換算	吐出量 (L/min)								
	全揚程 (m)								
	軸動力 (kW)								
粘度換算	吐出量 (L/min)								
	全揚程 (m)								
	軸動力 (kW)								
	ポンプ効率 (%)								
	マグネットポンプ効率 (%)								

電動機要目	
形式	IK-FCKLAW21E
出力 (kW)	0.4
周波数 (Hz)	50
電圧 (V)	200
電流 (A)	1.9
極数 (P)	2
回転速度 (min-1)	2800
製造番号	21070231016
製造業者名	TOSHIBA
試験揚液	常温清水
吐出量測定方法	電磁流量計
室温 (°C)	18
連続運転時間 (min)	60
軸受温度	
軸継手側 (°C)	-
反対側 (°C)	-
インペラー径 (mm)	122.0
マグネット形式	R25×6N-71
キャンロス (kW)	0.035
備考	
試験者名	島田
製造業者名	三和ハイドロテック(株)

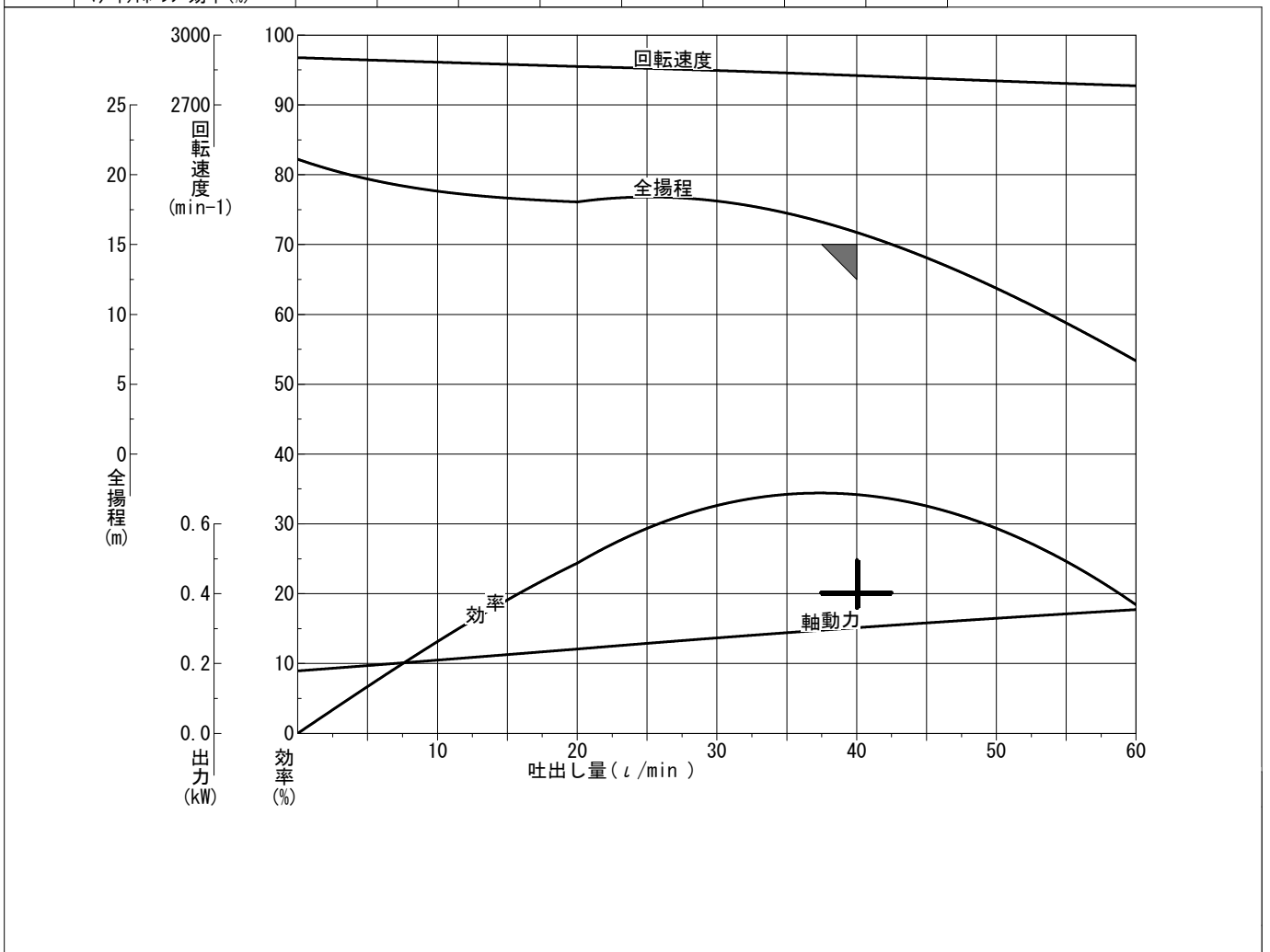

図面番号 DRAWING NO.
3HDB000111
 改訂/備考 REV. MARK
 ○

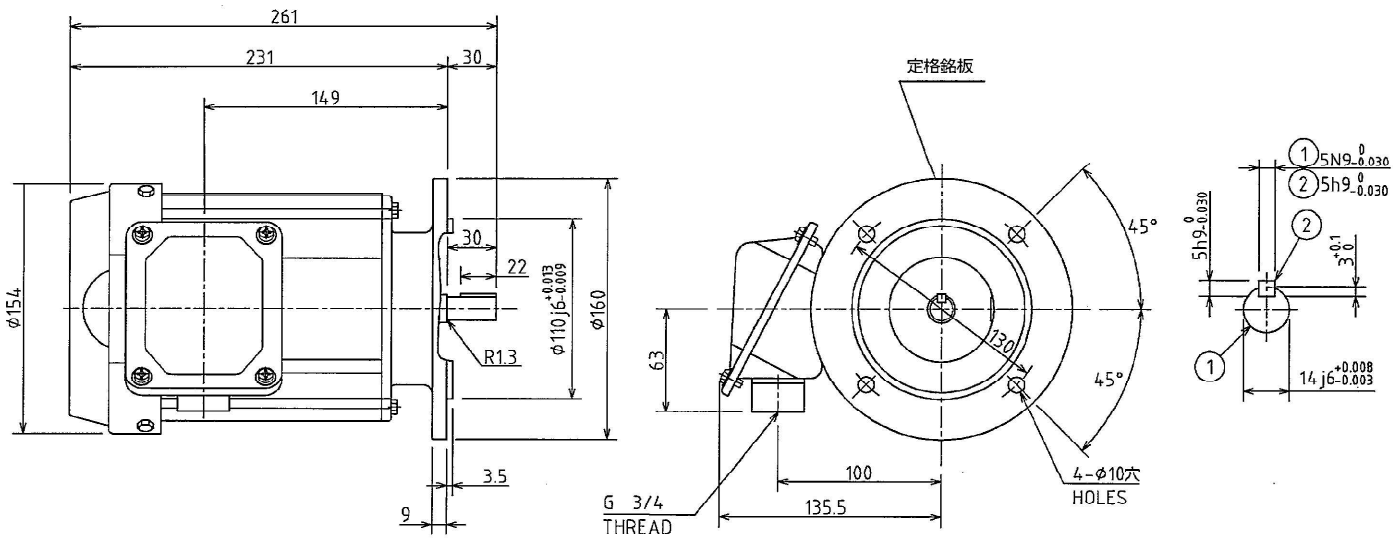

マンセル3.74BG3.04/1.25近似色(深緑)

保護方式 PROTECTION
IP44

出力 OUTPUT 0.4 kW	極数 POLES 2	電圧 VOLTS 200/200/220 V	周波数 FREQ. 50/60/60 Hz	回転速度 FULL LOAD SPEED 2800/3350/3400 min ⁻¹	軸受 BEARING 負荷側 LOAD SIDE 6203ZZC3 反負荷側 OPP.L.SIDE 6203ZZC3	概略質量 APPROX. MASS 本体 MOTOR 9.5 kg
形 TYPE IK	式 FORM FCKLAW21E	耐熱クラス THERMAL CLASS 120(E)	定格 RATING S1	枠番号 FRAME 71M	フランジ番号 FLANGE FF130	

記号 MARK 年月日 DATE	承認 APPROVED BY T.FURUICHI Dec. '16 '19	検図 CHECKED BY R.KATSUKI Dec. '16 '19	名称 TITLE 三相誘導電動機外形図 OUTLINE FOR THREE PHASE INDUCTION MOTOR	
承認 APPROVED BY 変更者 REVISED BY			設計 DESIGNED BY N.INAMURA Dec. '14 '19	製図 DRAWN BY M.YOSHIKADO Dec. '14 '19
記事 CONTENTS	TOSHIBA 東芝産業機器システム株式会社 TOSHIBA INDUSTRIAL PRODUCTS AND SYSTEMS CORPORATION		図面番号 DRAWING NO. 3HDB000111	
保管 REGISTERED	保管 REGISTERED		改訂/備考 REV. MARK ○	

3HDZ000011

REV. MARK
②

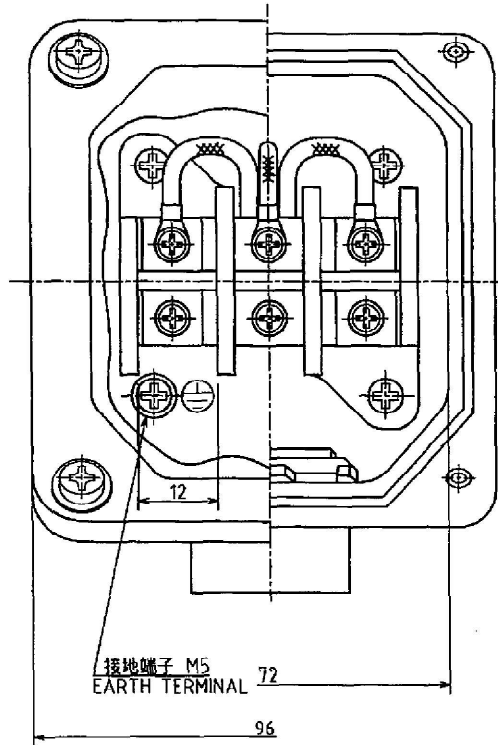
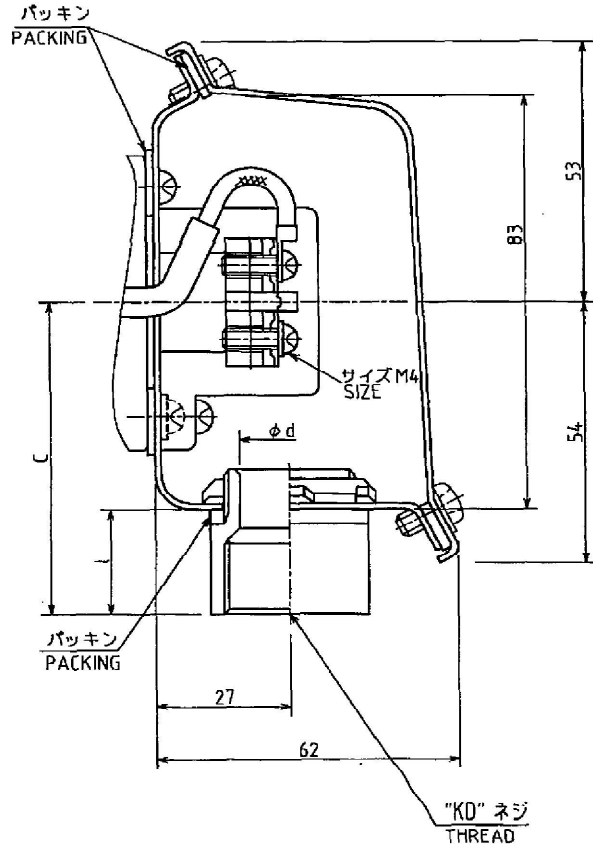

PNNo.	KD	C	l	d
1	G1	65	23	25
2	$G\frac{3}{4}$	63	21	20
3	$G\frac{1}{2}$	63	21	15

適用枠番号 63M ~ 112M
FRAME NO.

	②	①	記号MARK
	Feb. 14. 17	Aug. 10. 16	年月DATE
	T.FURUICHI	T.FURUICHI	承認APPROVED BY
	S.TAKAHASHI	S.ASAI	変更者REVISED BY
	CHG. COMPANY NAME.	ADD PNO.	
			記本CONTENTS
			保管REGISTERED

 尺貫 SCALE N.T.S. 単位 UNITS mm	承認 APPROVED BY T.FURUICHI Dec. 4. 12	検図 CHECKED BY N.TOJIMA Dec. 4. 12
	設計 DESIGNED BY M.OGAWA Dec. 4. 12	製図 DRAWN BY S.MATSUBARA Dec. 4. 12
	TOSHIBA 東芝産業機器システム株式会社 TOSHIBA INDUSTRIAL PRODUCTS AND SYSTEMS CORPORATION	
	保管 REGISTERED	

名称 TITLE 端子箱詳細図 CONSTRUCTION OF TERMINAL BOX
鋼板製 63M~112M 屋外形
図面番号 DRAWING NO. 3HDZ000011
REV. MARK ②