

MOTOR	
FRAME SIZE	OUTPUT (kW)
112M	3.7

MASS APPROX (kg)		
PUMP	MOTOR	TOTAL
38	36	74

- ① CASING DRAIN ; Rc3/8 (PLUG)
- ② FRAME ADAPTER DRAIN ; Rc1/4 (OPEN)

Item No. : \_\_\_\_\_  
 Pump Name : \_\_\_\_\_

FLANGE DIMENSIONS \* SMOOTH FINISH (mm)

RATING		SIZE(d)	D	t	f	g	C	n	h
JIS 10K RF	SUCTION	50mm	155	16	2	96	120	4	19
	DISCHARGE	40mm	140	16	2	81	105	4	19

REV.	
APP'D T.Shimayoshi	CH. M.Murakami
CHIEF <i>[Signature]</i>	DWN.M.Murakami
CH'D M.Murakami	DATE 2020.03.30

PUMP CODE  
 MP542-B56  
 MAGNETIC DRIVE  
 CENTRIFUGAL PUMP  
 OUTLINE DIMENSIONS

WORK No.	
QTY.	
DWG.No.	REV.
MP542-B56-X	1

3rd ANGLE PROJECTION SCALE  $\times$  SANWA HYDROTECH CORP.

承
審
品
機
組
1
控
計

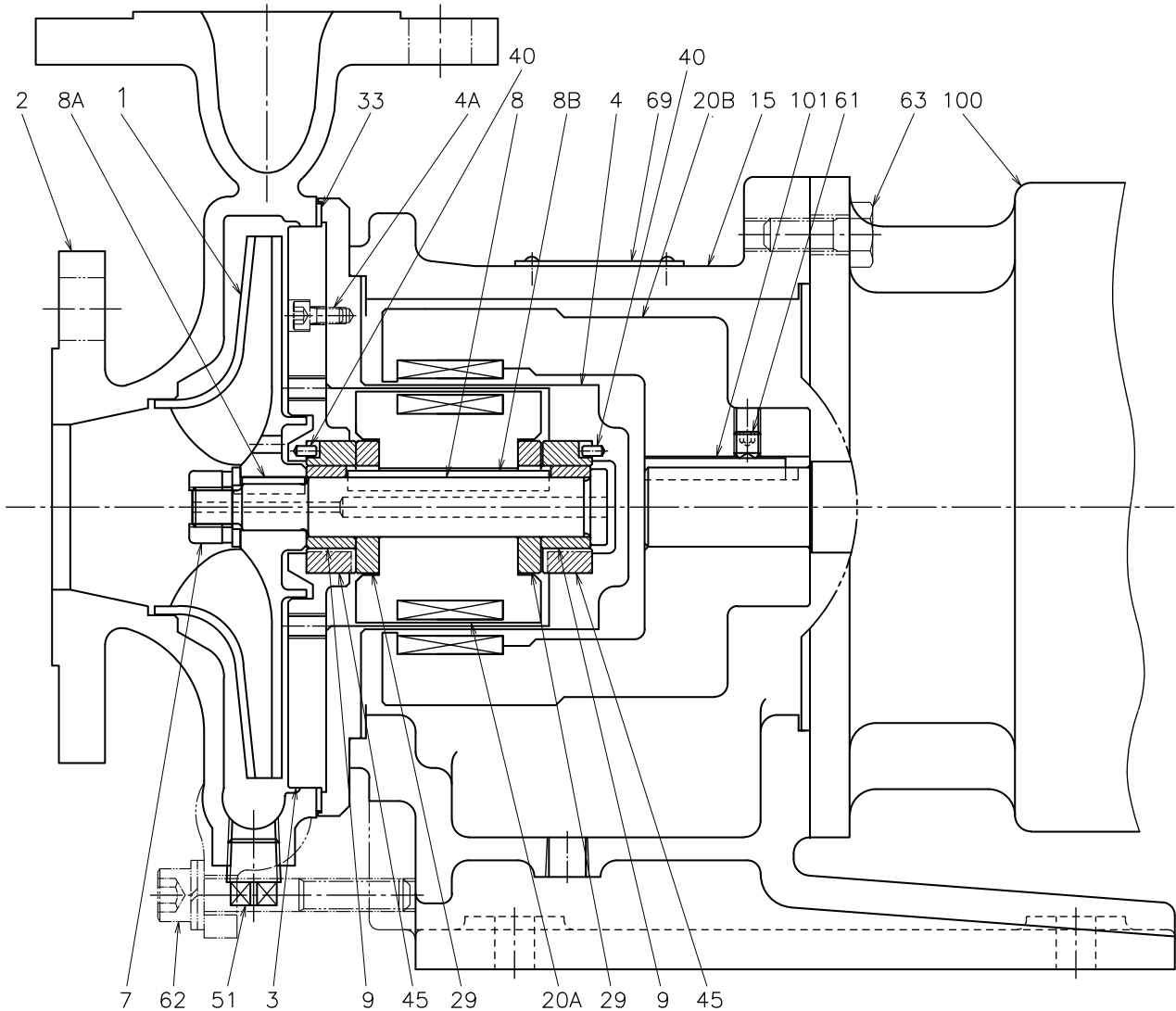

101	COUPLING KEY	—	1		
100	MOTOR	—	1		
69	NAME PLATE	SUS304	1		
63	HEXAGON HEAD BOLT	SUS304	4		
62	HEXAGON SOCKET HEAD CAP SCREW	SUS304	6 <sup>S</sup>		WITH WASHER
61	SET SCREW	SCM435	1		
51	PLUG	SUS316	1		R3/8
45	BUSHING	SiC	2		
40	PIN	SUS316	2		φ3x6L
33	GASKET	PTFE	1		φ 170 xφ 184 x1.5t
29	THRUST RING	SiC	2		
20B	MAGNET	RARE EARTH	1 <sup>S</sup>		
	MAGNET COUPLING(M)	FCD	1		K32N
20A	MAGNET	RARE EARTH	1 <sup>S</sup>		
	MAGNET COUPLING(P)	SUS316	1		K32N
15	FRAME ADAPTER	FC200	1		
9	SLEEVE	SiC-D	2		
8B	COUPLING KEY	SUS316	1		
8A	IMPELLER KEY	SUS316	1		
8	SHAFT	SUS316	1		
7	IMPELLER NUT	SUS316L	1 <sup>S</sup>		M12, WITH WASHER
4A	HEXAGON SOCKET HEAD CAP SCREW	SUS316L	4		
4	REAR CASING	SUS316	1		
3	CASING COVER	SUS316	1		
2	CASING	SCS14	1		
1	IMPELLER	SCS14	1		
MARK	NAME OF PART	MAT'L	USE No.REQ'D	SPARE	REMARK.

NAME OF PART	MAT'L	QTY.
ACCESSORIES		

REV.		
APP'D	T.Shimayoshi	CH. M.Murakami
CHIEF	<i>[Signature]</i>	DWN. M.Murakami
CH'D	M.Murakami	DATE 2020.03.30

PUMP CODE  
MP542-B56  
MAGNETIC DRIVE  
CENTRIFUGAL PUMP  
SECTIONAL DRAWING  
3rd ANGLE PROJECTION SCALE  $\times$

WORK No.	
QTY.	
DWG.No.	MP542-B56-0
REV.	

SANWA HYDROTECH CORP.

承  
審  
品  
機  
組  
控  
計

PUMP DATA SHEET				WORK No.				
1	CUSTOMER			DATE		2020/4/1		
2	USER			AUTH. BY	CHKD BY	MADE BY		
3	EQUIP' T NAME			T. Shimayoshi	M. M	M. Murakami		
4	ORDER No.			REV. DATE	LINE No.	BY		
5	JOB No.							
6	ITEM (PUMP) No.							
7	PUMP NAME							
8	QUANTITY							
9	OPERATING CONDITIONS				CONSTRUCTION			
10	LIQUID			PUMP CODE	MP542-B56			
11	SLURRY			MAGNET TYPE	K32N			
12		(wt%)	(mm)	BEARING	RADIAL :	-	THRUST : -	
13	PH			AUXILIARY PIPING	-			
14	PUMPING TEMP.	(-20~130)	( °C )	NOZZLE	SIZE	RATING	FACING	
15	SPEC. GRAVITY	@P. T.	1	SUCTION	50 (mm)	JIS 10K	RF	
16	VAPOUR PRESS.	@P. T.		DISCHARGE	40 (mm)	JIS 10K	RF	
17	VISCOSITY	@P. T.	1 (mPa · s)	IMPELLER DIA. DES.	φ 164 (mm)			
18	CAPACITY	15.6 (m3/hr)	260 (l/min)	ROTATION VIEWED FROM CPLG END	■ CW □ CCW			
19	DISCH. PRESS.			PERFORMANCE				
20	SUCT. PRESS.			SPEED	2950 (rpm)			
21	DIFF. PRESS.			NPSH REQ' D (WATER)	- ( m )			
22	TOTAL HEAD	30	( m )	DES. EFF.	47 ( % )			
23	NPSH AVAIL.			DES. BHP	2.7 ( kW )			
24	CASE DES. TEMP.	130 (°C)	PRESS. 1.0 (MPaG)	MIN. CONTINUOUS FLOW	2.1 (m3/hr)	35 (l/min)		
25	INSTALLATION	<input type="checkbox"/> INDOOR	<input type="checkbox"/> OUTDOOR					
26	MOTOR				MATERIALS			
27	TYPE	IKH3	FORM FCKLAW21E	CASING	SCS14			
28				IMPELLER	SCS14			
29	SPEED	3000 (SYN)	(rpm)	SLEEVE, BUSHING, THRUST RING	SiC-D, SiC, SiC			
30	VOLTS/CYCLE	200 ( V )	50 ( Hz )	SHAFT (HF)	SUS316 ( - )			
31	RATED OUTPUT/POLES	3.7 ( kW )	2 ( P )	GASKET	PTFE			
32	FRAME	112M	MFR. TOSHIBA	O RING	---			
33	PUMP PAINTING							
34	COLOR	BODY: 2.5PB4/10	COVER: ---					
35	REMARKS							
36								
37								
38								
39								
40								



# 〈試験成績表〉

CODE : MP542-B54/B56  
 PUMP TYPE : MP  
 PUMP SIZE : 542

発行日 : 2019.05.13  
 Rev.1 : 2020.04.01

規格要目	指定揚液 (温度 [°C]、比重、粘度) 10/1/1 [mPa·s]	吐出し量 (ℓ/min)	全揚程 (m)	回転速度 (min-1)	原動機出力 (kW)	NPSH <sub>Av</sub> /Req (m)
		260	30	2950	3.70	-/-

計測項目		1	2	3	4	5	6	7	8
回転速度 (min-1)		2977	2968	2958	2952	2946			
水温 (°C)		24.4	24.4	24.4	24.4	24.5			
吐出し量	測定器の読み (ℓ/min)	0.0	99.2	202.1	301.7	399.0			
	吐出し量 (ℓ/min)	0.0	99.2	202.1	301.7	399.0			
揚程	吐出しヘッド (m)	37.40	36.50	33.40	28.50	22.10			
	吸込ヘッド (m)	1.10	0.90	0.60	0.10	-0.50			
	測点高差 (m)	0.23	0.23	0.23	0.23	0.23			
	速度ヘッド (m)	0.000	0.047	0.194	0.431	0.754			
	全揚程 (m)	36.5	35.9	33.2	29.1	23.6			
	理論動力 (kW)	0.000	0.580	1.094	1.429	1.534			
周波数 (Hz)		50.0	50.0	50.0	50.0	50.0			
電動機	電圧 (V)	201.0	200.3	199.7	199.4	198.9			
	電流 (A)	6.350	7.526	8.954	9.937	10.839			
	入力 (kW)	1.536	2.067	2.637	3.000	3.325			
	効率 (%)	88.8	90.1	90.1	90.0	89.7			
	出力 (kW)	1.365	1.862	2.377	2.699	2.982			
軸動力 (kW) (比重=1)		1.365	1.862	2.377	2.699	2.982			
ポンプ効率 (%)		0.0	31.1	46.0	53.0	51.4			
回転換算	吐出し量 (ℓ/min)								
	全揚程 (m)								
	軸動力 (kW)								
粘度換算	吐出し量 (ℓ/min)								
	全揚程 (m)								
	軸動力 (kW)								
	ポンプ効率 (%)								
	マグネットポンプ効率 (%)								

付属試験用	電動機要目
形式	IKH3-FCKLAW21E
出力	( 3.7 kW)
周波数 (Hz)	( 50 Hz)
電圧	( 200 V)
電流	( 13.6 A)
極数	( 2 P)
回転速度	( 2910min-1)
製造番号	18030049934
製造業者名	TOSHIBA
試験揚液	常温清水
吐出量測定方法	電磁流量計
室温	( 25 °C)
連続運転時間	( 60 min)
軸受温度	
軸継手側	( - °C)
反対側	( - °C)
インペラー径	( 164 mm)
マグネット形式	K32N-112
キャンロス	( 0.340 kW)
備考	
試験者名	森安
製造業者名	三和ハイドロテック(株)

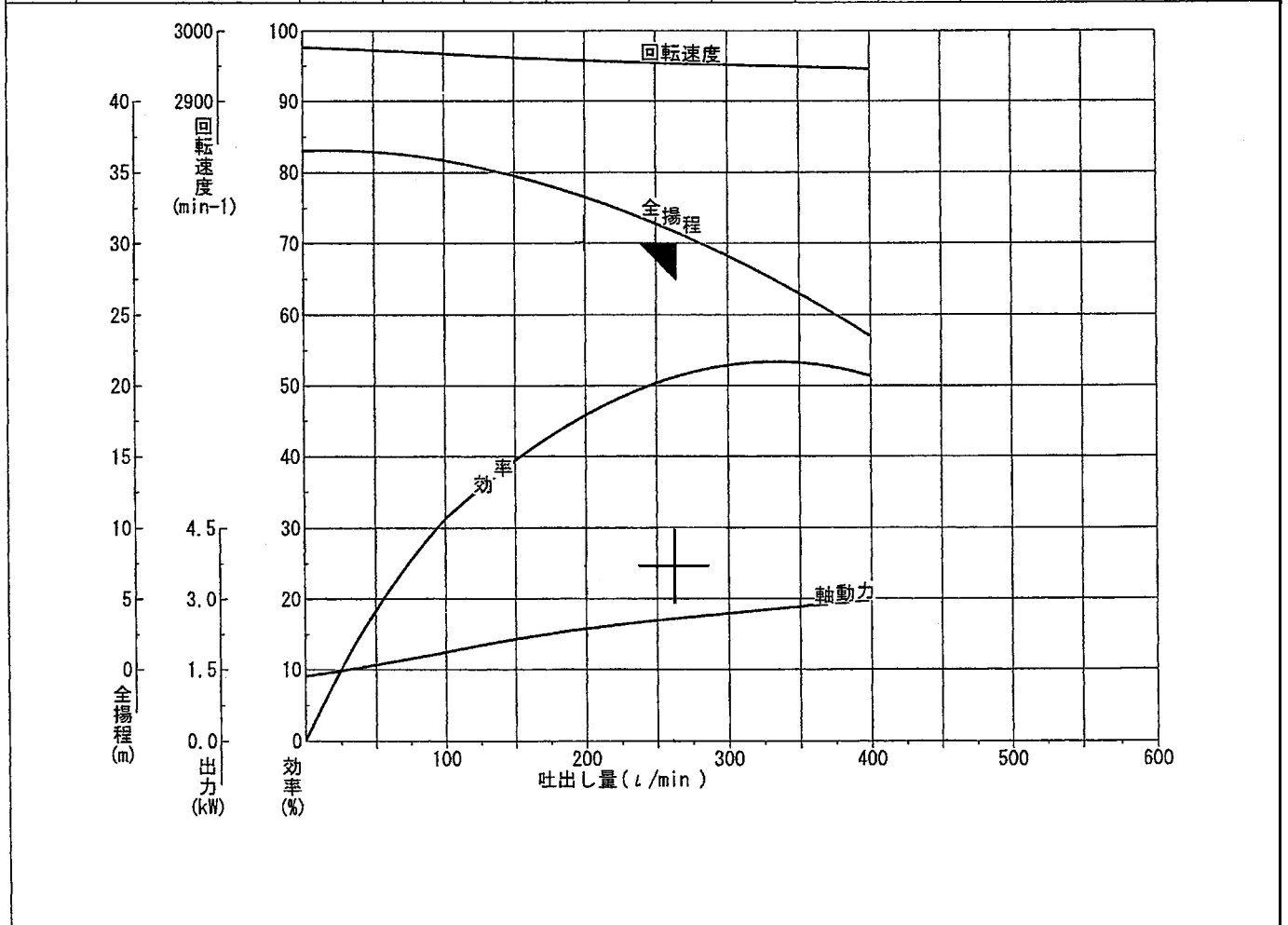

3HDA001964

図面番号 DRAWING NO.

REV.MARK

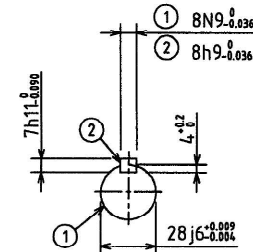
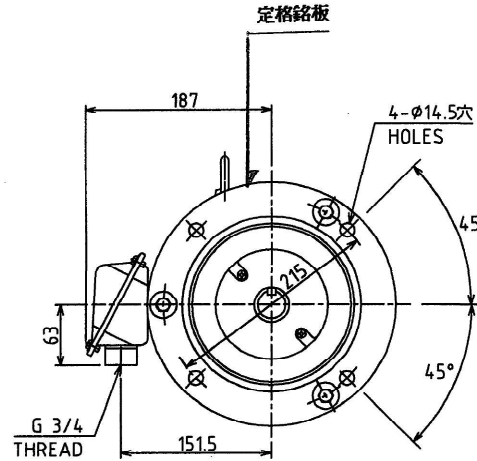
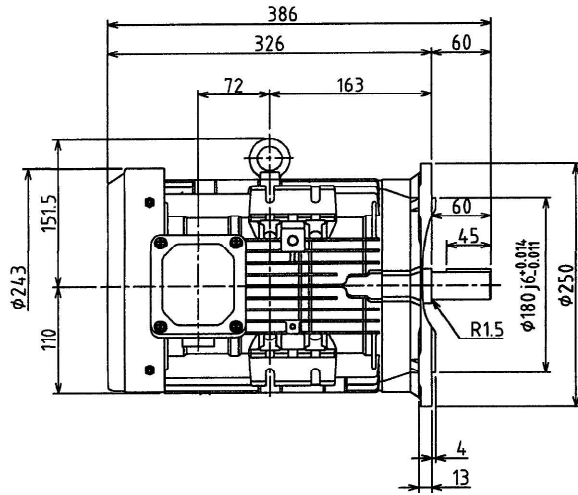

マンセル: 3.74BG3.04/1.25近似色(深緑)

保護方式 PROTECTION  
IP55

出力 OUTPUT 3.7KW	極数 POLES 2P	電圧 VOLTS 200/200/220 V	周波数 FREQ. 50/60/60 Hz	回転速度 FULL LOAD SPEED 2910/3490/3515 min <sup>-1</sup>	軸受 BEARING 負荷側 LOAD SIDE 6207ZZC3 反負荷側 OPPL.SIDE 6206ZZC3	概略質量 APPROX. MASS 本体 MOTOR 36 kg
形 TYPE IKH3	式 FORM FCKLAW21E	耐熱クラス THERMAL CLASS 155(F)	定格 RATING S1	枠番号 FRAME 112M	フランジ番号 FLANGE FF215	

記号 MARK		承認 APPROVED BY T.FURUICHI Aug. 31 '13	検閲 CHECKED BY T.NISHINO Aug. 31 '13	名称 TITLE <b>三相誘導電動機外形図</b> OUTLINE FOR THREE PHASE INDUCTION MOTOR	
年月日 DATE		尺度 SCALE N.T.S.	設計 DESIGNED BY Z.CAO Aug. 30 '13		製図 DRAWN BY Z.CAO Aug. 30 '13
承認 APPROVED BY		単位 UNITS mm			
変更者 REVISED BY					
記事 CONTENTS	変更 REVISIONS	<b>TOSHIBA</b> 東芝産業機器システム株式会社 TOSHIBA INDUSTRIAL PRODUCTS AND SYSTEMS CORPORATION		図面番号 DRAWING NO. <b>3HDA001964</b>	
保管 REGISTERED		保管 REGISTERED	M	REV.MARK	



REF.3HDA001674

配布先 PRESENT TO

3HDZ000011

REMARK  
②

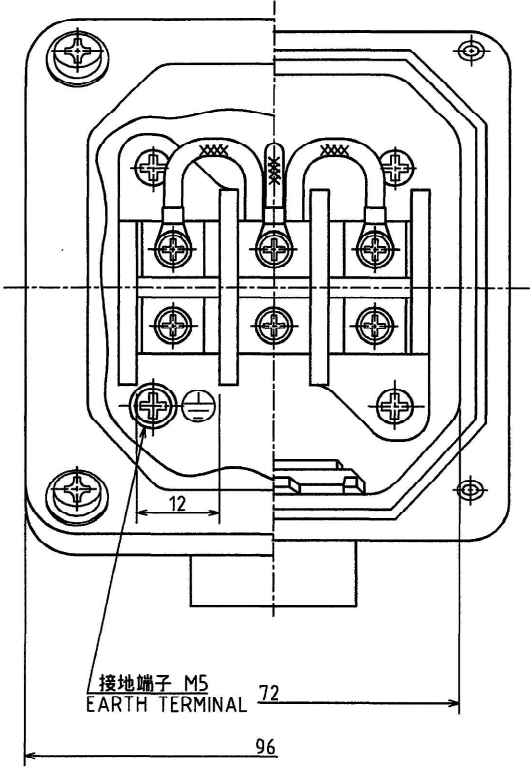
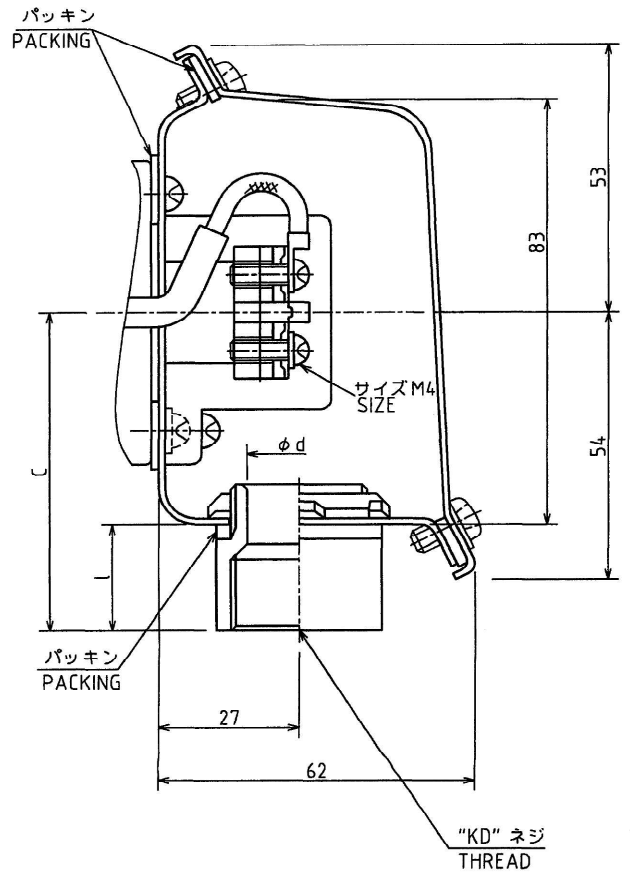

PNo.	KD	C	l	d
1	G1	65	23	25
2	$G\frac{3}{4}$	63	21	20
3	$G\frac{1}{2}$	63	21	15

適用枠番号 63M ~ 112M  
FRAME NO.

		②	①	記号MARK
		Feb. 14. 17	Aug. 10. 16	年月DATE
		T.FURUICHI	T.FURUICHI	承認APPROVED BY
		S.TAKAHASHI	S.ASAI	変更者REVISED BY
		CHG. COMPANY NAME.	ADD PNO.	記事CONTENTS
				保管REGISTERED

承認 APPROVED BY T.FURUICHI Dec. 4. 12  
 検図 CHECKED BY N.TOJIMA Dec. 4. 12  
 設計 DESIGNED BY M.OGAWA Dec. 4. 12  
 製図 DRAWN BY S.MATSUBARA Dec. 4. 12

尺度 SCALE N.T.S. 単位 UNITS mm

**TOSHIBA** 東芝産業機器システム株式会社  
 TOSHIBA INDUSTRIAL PRODUCTS AND SYSTEMS CORPORATION

名称 TITLE  
 端子箱詳細図  
 CONSTRUCTION OF TERMINAL BOX

鋼板製 63M~112M 屋外形

図面番号DRAWING NO.  
**3HDZ000011**

変更 REV.MARK  
 ②